

LTECH

Super Panel

Manual

www.ltech-led.com

 Bluetooth®   RoHS

Product Introduction

Super Panel is a central control panel that integrates all of your connected devices to control the entire smart home. Based on 5G speed with cloud computing, it has the powerful intelligent gateway function with Bluetooth 5.0 SIG Mesh technology and is compatible with Wi-Fi, Bluetooth 5.0 SIG Mesh and Ethernet.

Support button, touch, and mobile App control. Multiple scenes preset for any occasion can be quickly turned on or off merely through slight taps on the buttons.

Easily control your lighting, air conditioning, infrared home appliances, curtains and other items to build a complete smart home system.

Compatible with 86 type and European style standard junction boxes, no need to modify the wiring that can easily replace traditional switches.

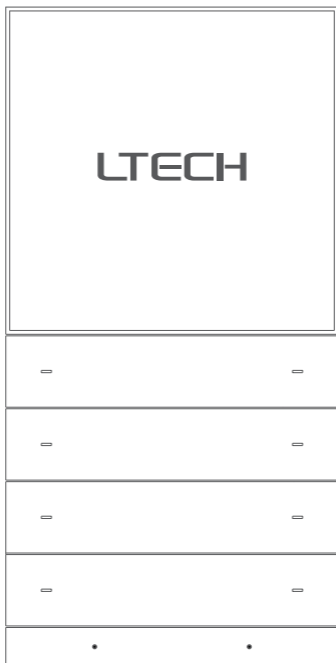

Technical Specs

Product model: SP-GW-BLE

Input voltage: 100-240Vac

Wireless network: Wi-Fi, Bluetooth 5.0 SIG Mesh

Wired network: Ethernet

Display: 4.0-inch full lamination, 720×720 resolution

Touchpad: Capacitive multi-touch screen, anti-fingerprint coating

Proximity sensor: Close-range sensing within 15cm, automatic wakeup

Light sensor: Adjust the screen brightness automatically when lighting changes

Working environment: Temperature -15°C~50°C, Humidity≤85%RH

Body materials: Aviation aluminum, CNC machining techniques,
PC + fiberglass, V0 fireproofing grade

Dimensions (L×W×H): 172×86×38mm

Junction boxes: 86 type, European style

Package Contents

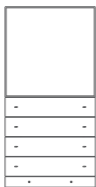

Super Panel×1

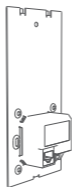

Base plate×1



Manual×1



KM4 screw×2



KA4 screw×2



PWA2 screw×2



KM2 screw×2



Expansion bolt×2

Application Diagram

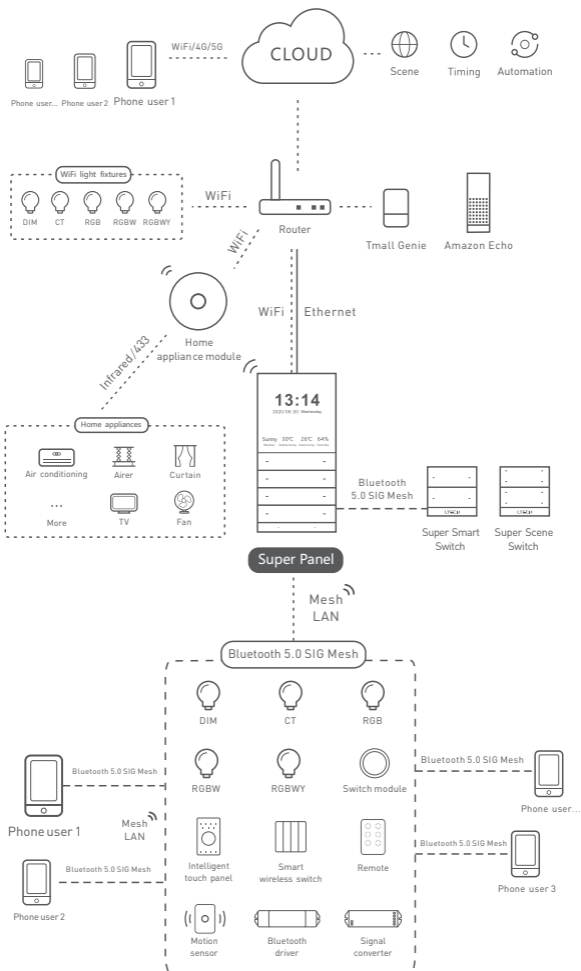

Recommended Applications

1.App control,gain fast control of lamps

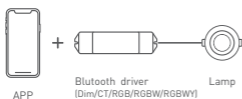

2. Both the remote and wireless switch can control lamps (With reliable and stable signals)

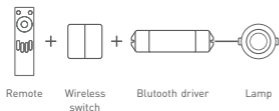

3.Wireless+wired control (Enriching different lighting applications)

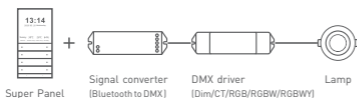

4. Super Panel supports both LAN+remote lighting control via 3G/4G/5G/Wi-Fi

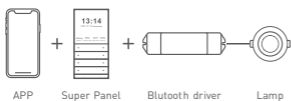

5. The Super Panel and home appliance module control lamps, air conditioning, curtains and other items (Customize cloud scenes and automatic applications)

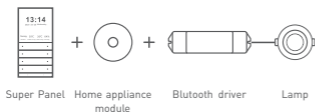

6. The Super Panel,remote and wireless switch can simultaneously control lamps

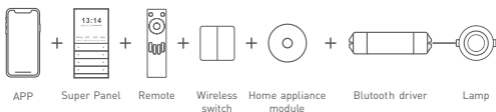

7. More applications of intelligent control are waiting for you to set up.

Product Images

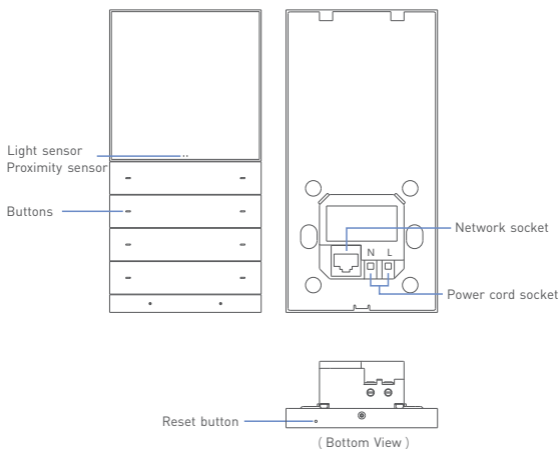

* Reset button: Long press it for 16s until the screen turns on and displays the LTECH LOGO.

Product Size Unit: mm

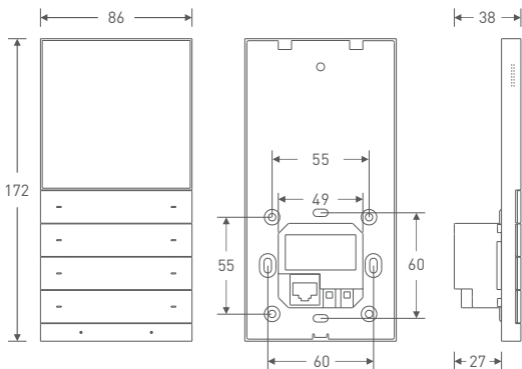

How to Install A Super Panel

1. Trim the power cord

Turn off the circuit breaker and remove any concrete or corrosion that are inside the wall box. Trim the power cord in the wall box to 10cm in length approximately.

2. Fix the bottom of base plate

Attach the null line to N socket and live line to L socket, as shown in the diagram below. If necessary, insert a network cable into the network socket. Fix the bottom of base plate to the wall box and tighten the screws to secure it to the box.

Note: Make sure the base plate is stable and won't appear crooked.

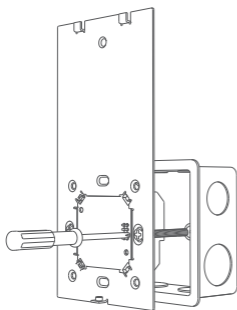
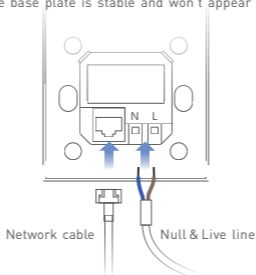

Install the 86 type junction box with KM4 screws

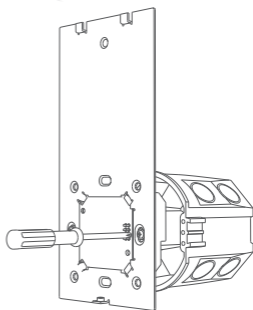

Install the European standard junction box with PWA2 screws

Attentions

- The installation location should avoid being close to large-area metal objects against signal interference.
- Please use in a cool and dry environment.
- Please keep away from heat.
- Please do not open, change or repair, otherwise the warranty is not allowed.

3. Adjust the base plate

Insert the expansion bolt into the upper side of base plate, and place the KA4 screw into the bolt. Secure the KA4 screw to fit the base plate to the wall with a screwdriver. Otherwise, improper installation may cause damage to the product.

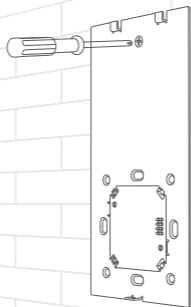

4. Put the Super Panel cover in place

Slant the bottom of Super Panel cover and put it in place, as shown below. Then secure the Super Panel cover to the base plate from the bottom with a KM2 screw.

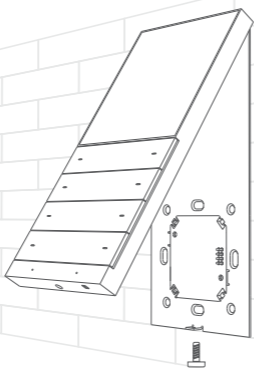

KM2 screw

Instructions to Use SuperPanel

1. Swipe gesture control

- ① After Super Panel adding devices and scenes, the system will automatically generate different types of pages. You'll be able to swipe left and right to switch to any device page.
- ② Swipe down from the top of screen to access the control center; swipe up to close it.
- ③ Swipe up from the bottom of screen to access the button usage guidelines; swipe down to close it.

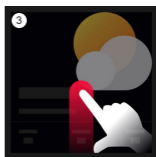
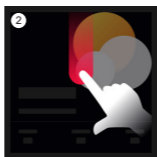
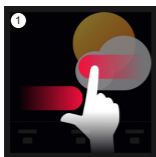

2. Physical buttons

There are eight physical buttons on the panel. The App allows you to bind a device action or scene to each button. For more details, please refer to P12. You'll be able to swipe up from the bottom of screen to go to the button usage guidelines and view the functionality of each button; swiping down lets it close.

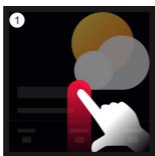

App Operating Instructions

1. Register an account

1.1 Scan the QR code below with your mobile phone and follow the prompts to complete the app installation.



Scan and download the App

1.2 Open the App and log in or register an account.

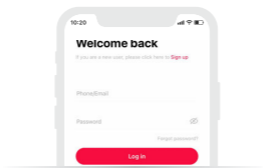

2. Configure the Super Panel

Power on the Super Panel and wait for a while to start it. Follow the page guidelines of panel to connect the Wi-Fi. Once connected successfully, a QR code for the device will be displayed on the interface and you'll be able to complete the configuration.

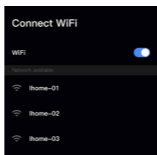
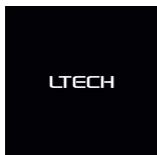

3. Bind your account

Open the APP and create a home if you are a new user. Click "+" icon in the upper right corner and access the "Add Device" list. Pick "Intelligent Gateway-Super Panel" from the "Add Device" list and follow the prompts to scan the QR code displayed on the Super Panel screen, then complete your account binding.

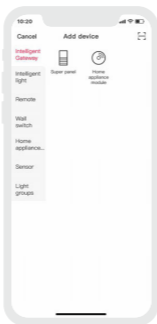
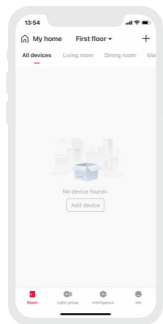

4. How to control lights, infrared appliances and other items with Super Panel

Please refer to manuals of related products. Follow the prompts to add the devices you want and access the Super Panel interface. Click "Device" and go to "Displayed Devices" interface. Click the icon in the upper right corner, pick the devices you want to control with the panel and save them. If you want to control bluetooth devices, please connect the Super Panel to bluetooth network before you start to bind home devices to the panel. Go to the Super Panel interface and click "Bluetooth Configuration". Then follow the prompts to configure the Super Panel to bluetooth network.

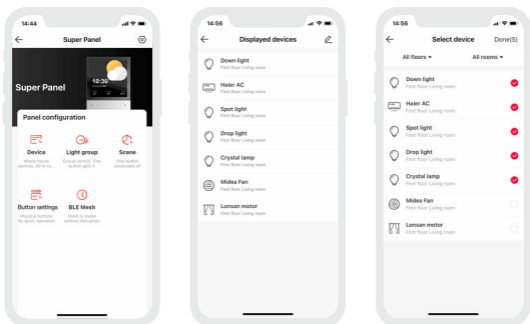

5. How to control light groups with Super Panel

Please refer to manuals of related products. Follow the prompts to add the devices you want and group the same type of light together. Go to the Super Panel interface and click "Light Group" to access "Displayed Light Groups" interface. Click the icon in the upper right corner and pick the groups you want to control with the panel.

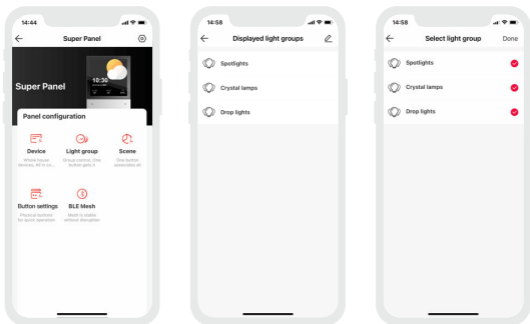

6. How to control cloud scenes with Super Panel

Create scenes: Get back to the homepage of the App. Switch to “Intelligence” menu and click “+” icon to add scenes. Follow prompts to modify names and icons for scenes, and click “Add Action” to set up the action and delay time you want. **Displayed scenes:** Go to the Super Panel interface and click “Scene” to access “Displayed Scenes” interface.

Click the icon in the upper right corner to add the scenes you want to control with the Super Panel.

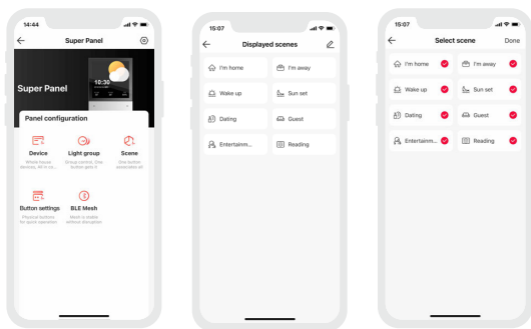

7. Physical button settings

Go to the Super Panel interface and click “Button settings” to set up. Click the button you want and follow the prompts to set up the device action or scene performed by this button.

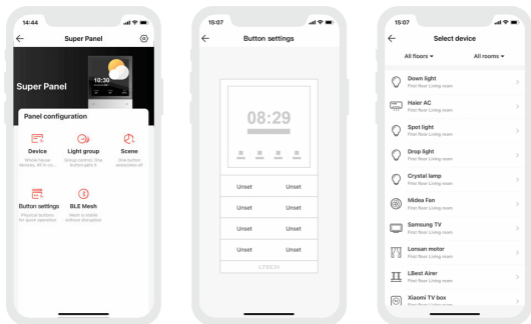

FAQs

1. What should I do if I fail to configure the device to the Internet?

- 1.1 Please make sure the device is powered on normally.
- 1.2 Please make sure the device hasn't been added by any other account.
If it did, please delete it on the APP and add it again.
- 1.3 Please keep your mobile phone, device and router as close as possible.
- 1.4 Please make sure your router account and password are correct, and the router works with network available.

2. How to change user accounts?

Super Panel has one standard user account only. The Super Panel that has been added needs to be deleted by the original owner before your login.

* This manual is subject to changes without further notice. Product functions depend on the goods. Please feel free to contact our official distributors if you have any question.

Warranty Agreement

Warranty periods from the date of delivery : 2 years.

Free repair or replacement services for quality problems are provided within warranty periods.

Warranty exclusions below:

- Beyond warranty periods.
 - Any artificial damage caused by high voltage, overload, or improper operations.
 - Products with severe physical damage.
 - Damage caused by natural disasters and force majeure.
 - Warranty labels and barcodes have been damaged.
 - No any contract signed by LTECH.
1. Repair or replacement provided is the only remedy for customers. LTECH is not liable for any incidental or consequential damage unless it is within the law.
 2. LTECH has the right to amend or adjust the terms of this warranty, and release in written form shall prevail.

LTECH

Super Panel

超 级 面 板

使用说明书

www.ltech.cn

 Bluetooth®   RoHS

欢迎使用

Super Panel 是一款全宅智能家居控制面板，基于5G时代云计算算法，内置强大的蓝牙5.0 SIG Mesh 智能网关功能，兼容Wi-Fi，蓝牙5.0 SIG Mesh，以太网多种通讯方式。

集不同控制设备的功能于一身，实现一个面板控制全屋智能家居，整合按键、触摸、语音和APP四种交互方式。只需通过语音或按键，即可快速打开或关闭预定义的多种生活情景模式。

提供智能照明、空调、红外家电、背景音乐、智能窗帘等控制和管理服务，构成完整的智能家居系统。

安装兼容国标86、欧洲标准底盒，无需改造布线，即可轻松替换传统开关。

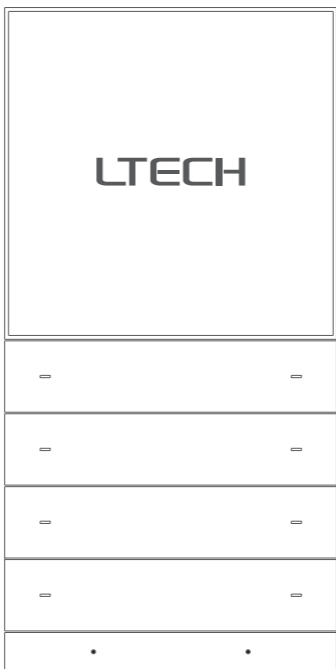

技术参数

产品型号：SP-GW-BLE

输入电压：100-240Vac

无线网络：Wi-Fi，蓝牙5.0 SIG Mesh

有线网络：Ethernet

显示屏：4.0英寸全贴合，720×720分辨率

触摸层：电容式多点触摸屏，防指纹涂层

麦克风：双麦克风阵列

扬声器：AAC 1813 喇叭

距离传感器：15cm近距离感应，自动唤醒

光线传感器：屏幕亮度适应环境光照

工作环境：温度-15°C~50°C，湿度≤85%RH

机身材质：航空铝材CNC工艺，PC+玻纤V0防火级别

产品尺寸：172×86×38mm

安装底盒：国标86底盒、欧洲标准底盒

包装清单

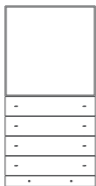

超级面板×1

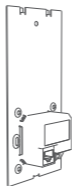

底壳组件×1



说明书×1



KM4螺丝×2



KA4螺丝×2



PWA2螺丝×2



KM2螺丝×2



膨胀螺栓×2

应用图

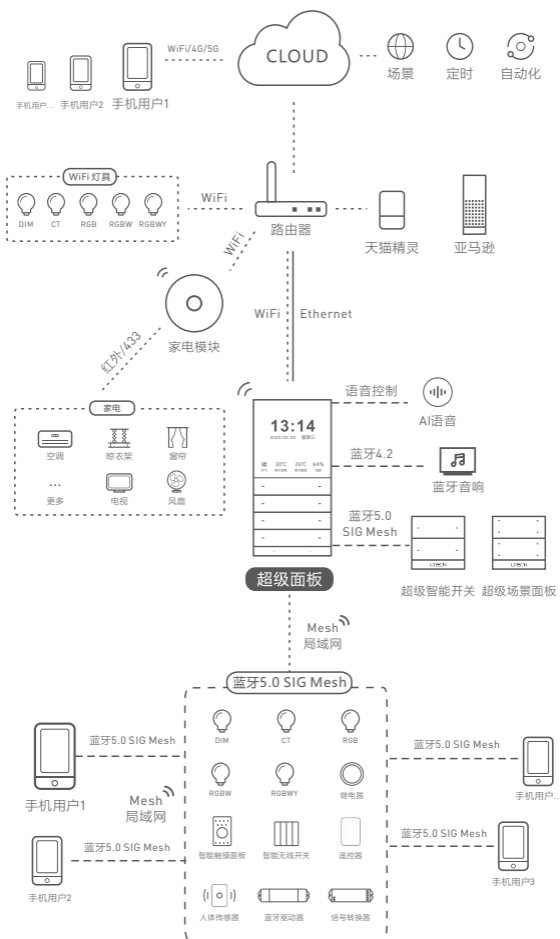

推荐应用搭配

1. APP无线控制，快捷控制灯具。



2. 遥控，面板控制灯具，信号稳定可靠。

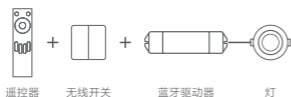

3. 无线+有线控制，丰富不同灯光应用。

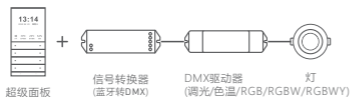

4. 超级面板，远程 (3G, 4G, 5G, WIFI) + 本地局域网双模控制灯具。

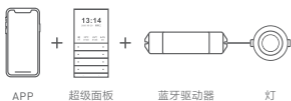

5. 超级面板，灯光与家电模组控制灯具，空调、窗帘电机等设备，定义云场景和自动化应用。



6. 多点控制，既能面板，遥控，无线开关同时控制灯具。



7. ...智能控制，更多应用搭配等您来设置。

产品图示

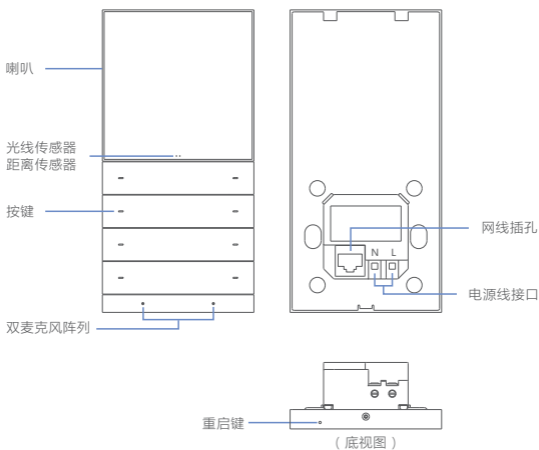

* 重启键：长按16秒，直至屏幕重新点亮显示LTECH LOGO

产品尺寸 单位: mm

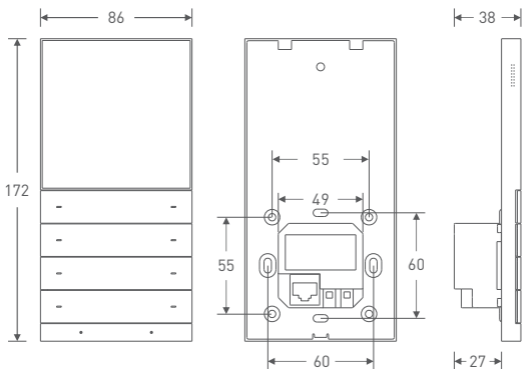

拆装方法

1. 剥电源线

关闭电闸，并确认暗盒内壁无水泥等附着物；将暗盒内的电源线长度修剪到10cm左右。

2. 安装底壳

将火线接入底壳L接口、零线接入底壳N接口；如需接网线，将网线接入网线插孔。底壳组件装入暗盒，用螺丝将底壳组件固定在暗盒上。
注意：固定好支架使其不晃动，并保持平整不变形。

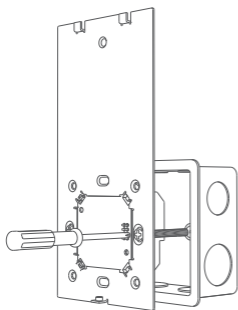
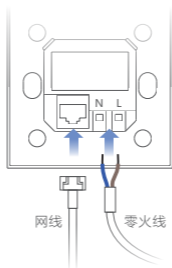

使用KM4螺丝安装国标86底盒

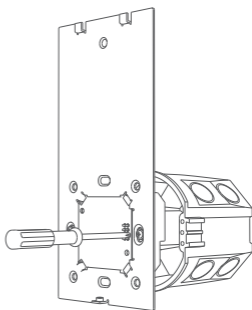

使用PWA2螺丝安装欧洲标准底盒

注意事项

- 安装位置注意避免靠近大面积金属物体，以免信号干扰影响使用。
- 不能在潮湿环境中使用。
- 禁止灼烧，远离热源。
- 请勿打开、改动、修理或维护本产品，否则不予保修。

3.调整支架

在支架上方螺丝孔位装入膨胀螺栓后使用KA4螺丝使支架贴合墙面。否则会导致面板安装不当，可能导致损坏。

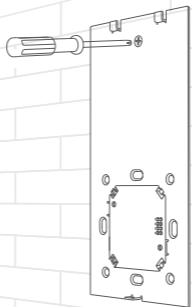

4.扣合面板

倾斜面板并扣合在支架上，用KM2螺丝从面板底部将面板支架锁紧。

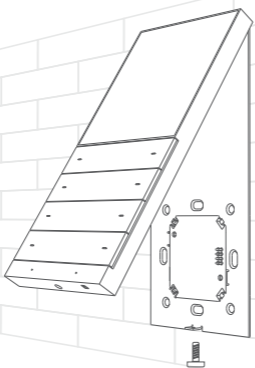

KM2螺丝

使用说明

一、手势操作

- ① 超级面板添加设备和场景后，系统将自动生成不同类型的页面，您可以通过左右滑动屏幕切换设备卡片。
- ② 从屏幕顶部向下滑动，可展开控制中心；向上滑动可收起。
- ③ 从屏幕底部向上滑动，可展开物理按键指引；向下滑动可收起。

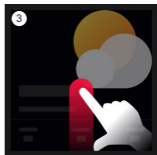
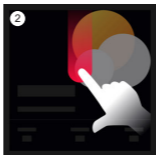

二、语音控制

可以通过唤醒词“你好小雷”和“小雷小雷”来唤醒语音技能，不仅可以语音控制设备，还可以听音乐，听新闻等等。更多功能，请打开超级面板APP界面，进入“语音技能”了解更多。



三、物理按键

面板共有八个物理按键，您可以在APP上绑定设备动作/场景到各个按键。详情请查看P12。

您可以从屏幕底部向上滑动，可展开物理按键指引，查看对应按键的功能；向下滑动可收起指引。

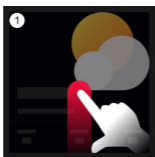

APP操作指引

1. 账号注册

1.1 通过手机扫描下方二维码，按提示完成APP安装。



扫码下载APP

1.2 打开APP进行登录/注册操作。



2. 配置超级面板

将超级面板接通电源，等待设备启动。根据超级面板页面指引，连接设备工作的WiFi。连接成功后，界面呈现出设备二维码，完成配置。

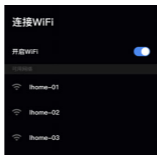
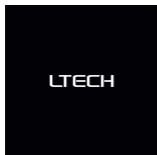

3. 账号绑定

打开APP，新用户创建家庭后，点击右上角“+”进入添加设备列表，在添加设备列表选择“智能网关-超级面板”后，按照界面提示，扫描超级面板上的二维码，完成绑定。



4. 如何在面板上控制灯具、红外家电等

请参照相关产品的说明书，按照提示添加完成设备后，进入超级面板的界面，点击“设备”进入显示设备界面。点击右上角图标，勾选您要在超级面板上控制的设备后，保存即可在超级面板上控制该设备。

如需控制蓝牙设备，请先将超级面板进入蓝牙网络后再进行绑定操作。进入超级面板的界面，点击“蓝牙配置”，按照提示操作完成蓝牙网络配置即可。



5. 如何在面板上控制灯组

请参照相关产品的说明书，按照提示添加完成设备后，将同类型灯具群组成组后，进入超级面板的界面，点击“灯组”进入显示灯组界面。点击右上角图标，添加您要在超级面板上控制的灯组即可。

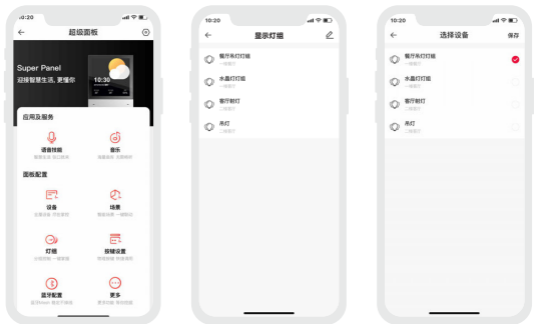

6. 如何在面板上控制云场景

创建场景：切换到“智能”菜单，选中“场景”，点击右上角“+”创建场景，按照提示可以修改场景名称、图标等。点击“添加动作”设定您想要的动作以及延时时间。

显示场景：进入超级面板界面，点击“设备”进入显示场景界面。点击右上角图标，添加您要在超级面板上控制的场景即可。

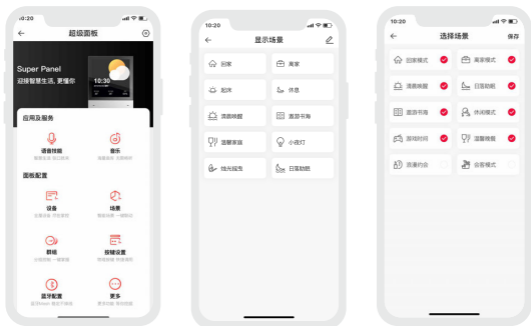

7. 物理按键设置

进入超级面板的界面，点击“按键设置”进入设置界面。点击对应的按键，按照提示可以设置当前按键执行的设备动作/场景。



8. 如何开通音乐功能

首年免费领取音乐畅听卡，随时在线畅听千万首正版高品质音乐。
进入超级面板的界面，点击“音乐”进入音乐服务界面。按照界面提示登录酷狗音乐后，领取音乐畅听卡即可。



常见问题及回答

1. 设备配网失败怎么办？

- 1.1 确保设备正常通电；
- 1.2 需要添加的设备未被其他账号添加过，如被添加过，请在APP上删除后重新添加；
- 1.3 确保手机、设备与路由器三者尽量靠近；
- 1.4 检查路由器账号和密码是否正确，路由器是否工作正常，网络畅通；

2. 如何更换账号？

超级面板采用一对一账号体系，被添加过的超级面板需要原主人删除后，才能重新添加。

* 本说明书的内容如有变更，恕不另行通知。若内容与您使用的功能有所不同，则以实物为准。如有疑问，欢迎向我司授权的经销商咨询。

保修条例

- 自出厂之日起保修服务期为2年。
- 在保修服务期内出现产品质量问题雷特将给予免费修理或更换服务。

非保修条例：

属下列情况不在免费保修或更换服务范围之内：

- 已经超出保修期限的；
- 过高电压、超负载、操作不当等人为造成的损坏；
- 产品外形严重损坏或变形；
- 自然灾害以及人力不可抗拒原因造成的损坏；
- 产品保修标签和产品唯一条形码损坏；
- 无雷特签订的合同或发票凭证。

1. 修理或更换是雷特对客户唯一补救措施。雷特不承担任何附带引起的损害赔偿，除非在适用法律范围之内。
2. 雷特享有修正或调整本保修条款的权利，并以书面形式发布为准。