

2. The detailed definition of the button

Sign	Button	Description
	ON/OFF	ON/OFF: Turn on/off the controller. Any button can start the controller at off status
	DELAY OFF	Press this key, it will wait 30 seconds before turning off the light automatically
	BRT+	Brightness +: Brightness up, pressing for fine dimming. Pressing still for fast dimming.
	BRT-	Brightness -: Brightness down, pressing for fine dimming. Pressing still for fast dimming.
	HOTKEY	Press these four keys can select different brightness you want directly & immediately.

8. Exception Handles

Malfunction	Causation	Solution
No Light	1.No power from the socket 2.Reverse connection of power +/- 3. Wrong or loose connection	1.Check the socket 2. Modify the connection 3. Check connection
Brightness of the LED is not even	1.Output wire too long, voltage drops 2. Wire diameter too slim, voltage drops. 3. Power supplier overloads 4. Controller overload	1. Reduce cable or use loop connection. 2. calculate the current and change to a wider wire 3. Change to another large power supplier 4. Add a power repeater
Cannot Remote	1. Remote battery is low. 2. Over remote distance	1. Replace a new battery 2. Reduce remote distance

9. After-Sales

From the day you purchase our products within 3 years, if being used properly in accordance with the instruction, and quality problems occur, we provide free repair or replacement services except the following cases:

- 1.Any defects caused by wrong operations.
- 2.Any damages caused by inappropriate power supply or abnormal voltage.
- 3.Any damages caused by unauthorized removal, maintenance, modifying circuit, incorrect connections and replacing chips.
- 4.Any damages due to transportation, breaking, flooded water after the purchase.
- 5.Any damages caused by earthquake, fire, flood, lightning strike etc force majeure of natural disasters.
- 6.Any damages caused by negligence, inappropriate storing at high temperature and humidity environment or near harmful chemicals.
- 7.Product has been updated.

Constant Voltage LED Dimmer User Manual



(Please read through this manual carefully before use)

1. Brief Introduction

LED intelligent dimmer is dedicated to adjust the brightness of LED lights, which adopted the most advanced PWM (Pulse-Width Modulation) digital brightness-adjusting technology at present. It's suitable for adjusting the brightness of low-power and hi-power LED illumination lights LED bar, LED lamp tape, SMD soft light bar, wall lamp, LED spotlights, LED lamp, LED droplight etc., It's real 0~100% brightness adjusting, 4096 scale levels. It works more advantageous especially in low brightness. Welcome to compare.

2. Specifications

Model	Constant Voltage 4A
Input power	DC12V~DC24V
Output signal	Constant voltage PWM
Max load current	4A
Output power	48W(12V) 96W(24V)
Dimming range	0-100%
Grey step	4096 levels
Remote control distance	RF, 30m with obstacles;60m without obstacles
Switch size	L72xW36x H25(mm)
Gross weight	90g

3. Basic Features

1. Automatically adapt to LED light which works from DC12V-24V.
2. Real 0~100% brightness adjust, 4096 scale levels. Comfort to human eye visual characteristic. Lamplight soft and stable, without flickers, welcome to compare.

3. Delay off button, users friendly.
4. 25%. 50%. 75%. 100% 4 brightness shortcuts.
5. Flexible, easy to install.
6. Working with power repeater to expand power output unlimitedly.
7. Power loss memory function.

4. Safety warnings

- Please don't install this controller in lightning, intense magnetic and high-voltage fields.
- 1.To reduce the risk of component damage and fire caused by short circuit, make sure correct connection.
 - 2.Always be sure to mount this unit in an area that will allow proper ventilation to ensure a fitting temperature.
 - 3.Check if the voltage and power adapter suit the controller. (please select DC12-24V power supply with constant voltage)
 - 4.Don't connect cables with power on; make sure a correct connection and no short circuit checked with instrument before power on.
 - 5.Please don't open controller cover and operate if problems occur.The manual is only suitable for this model; any update is subject to change without prior notice.

5. Dimensions

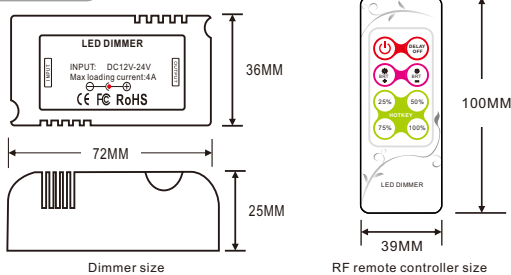

6. Conjunction Diagram

1)Connecting to LED strip:

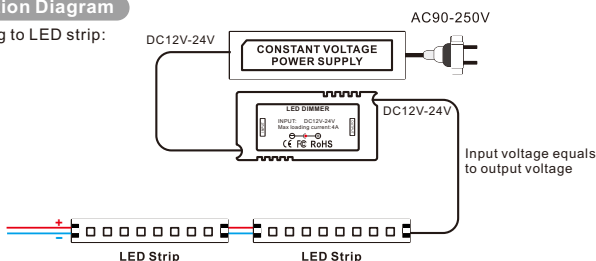

2)Connecting to power amplifier (the dimmer and the amplifier can share the same power supply):

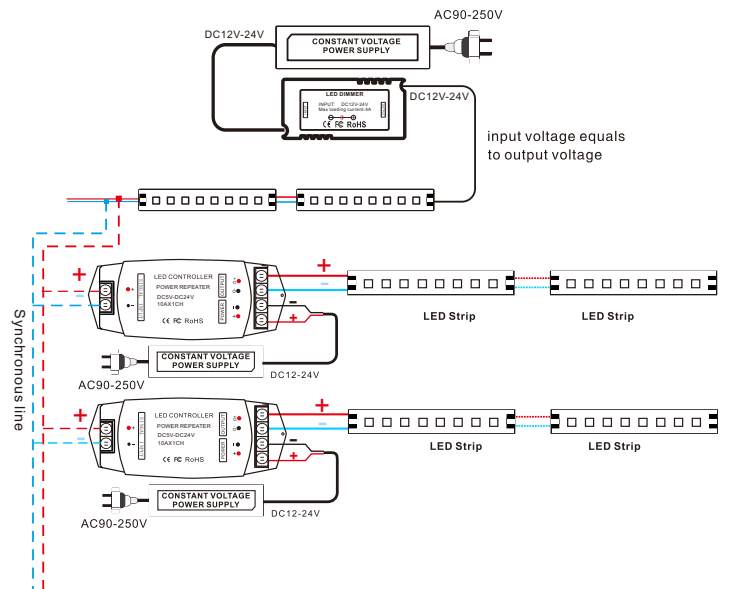

7. Operating instructions

1.About the button:

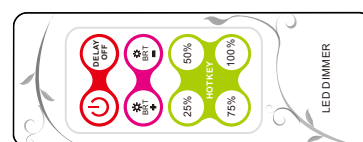

The remote control ID learning guide: Press ON/OFF button till the light flashes, then press DELAY OFF button, the light flashes again, the ID is set.